

# Collimation of Newtonian Telescope without *special* tools

So, you've got a new telescope, and want to get the best performance from it. Aside from atmospheric turbulence and tube current, the single most important factor degrading optical performance is bad collimation. This is especially important for Newtonian-design telescopes having "fast" focal ratios ( $f$ /numbers below  $f/7$ ). And while telescope manufacturers do a commendable job of aligning their units before they leave the factory, the need for recollimation often arises.

There are a number of tools on the market to aid in the collimation process. Most work fairly well, but nearly all require some degree of education and familiarity with telescope theory to be used effectively. Unfortunately, some people face the prospect of collimating their telescopes without immediate access to the tools or the knowledge of how to use them. This article is intended to guide a relatively inexperienced telescope user through a rough collimation process in which expensive additional tools are not required to obtain a workable collimation. Along the way, some attempt will be made to show why the process is necessary, without however, going into great amounts of theory or mathematical derivations.

## The "Ideal"-ized View of a Well Collimated Newtonian

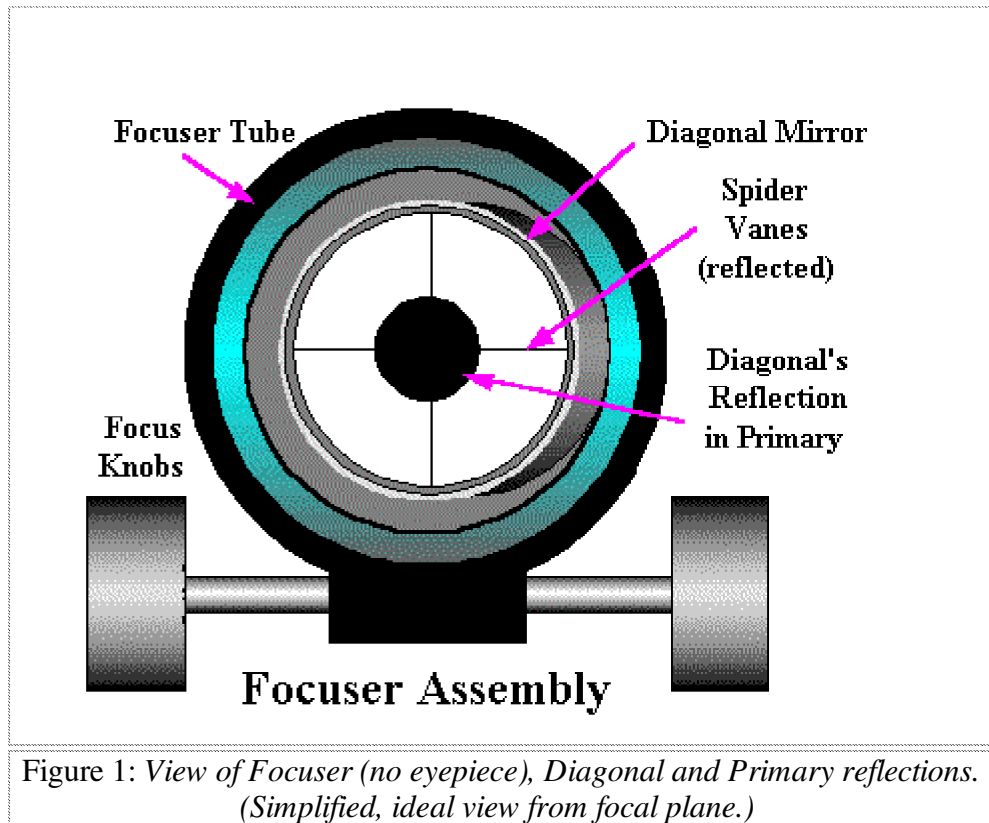

Figure 1: View of Focuser (no eyepiece), Diagonal and Primary reflections.  
(Simplified, ideal view from focal plane.)

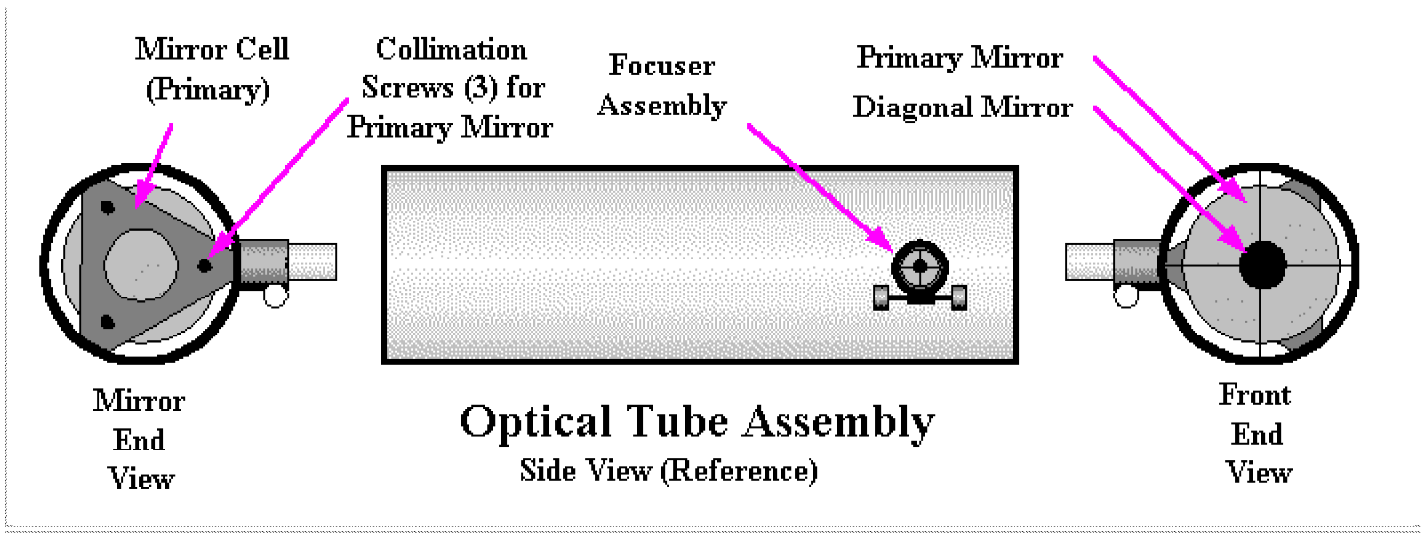

Figure 1a: Three Views of the Telescope (Orientation reference)

### Understanding the Diagrams

Comprehending the various circles and lines shown in the Focuser View illustrations, can be frustrating for both new and experienced telescope users, since actual photographs are not included. Even if they were, they might not accurately reflect the user's particular equipment or set up. With this in mind, the following set of explanatory diagrams are offered as a guide.

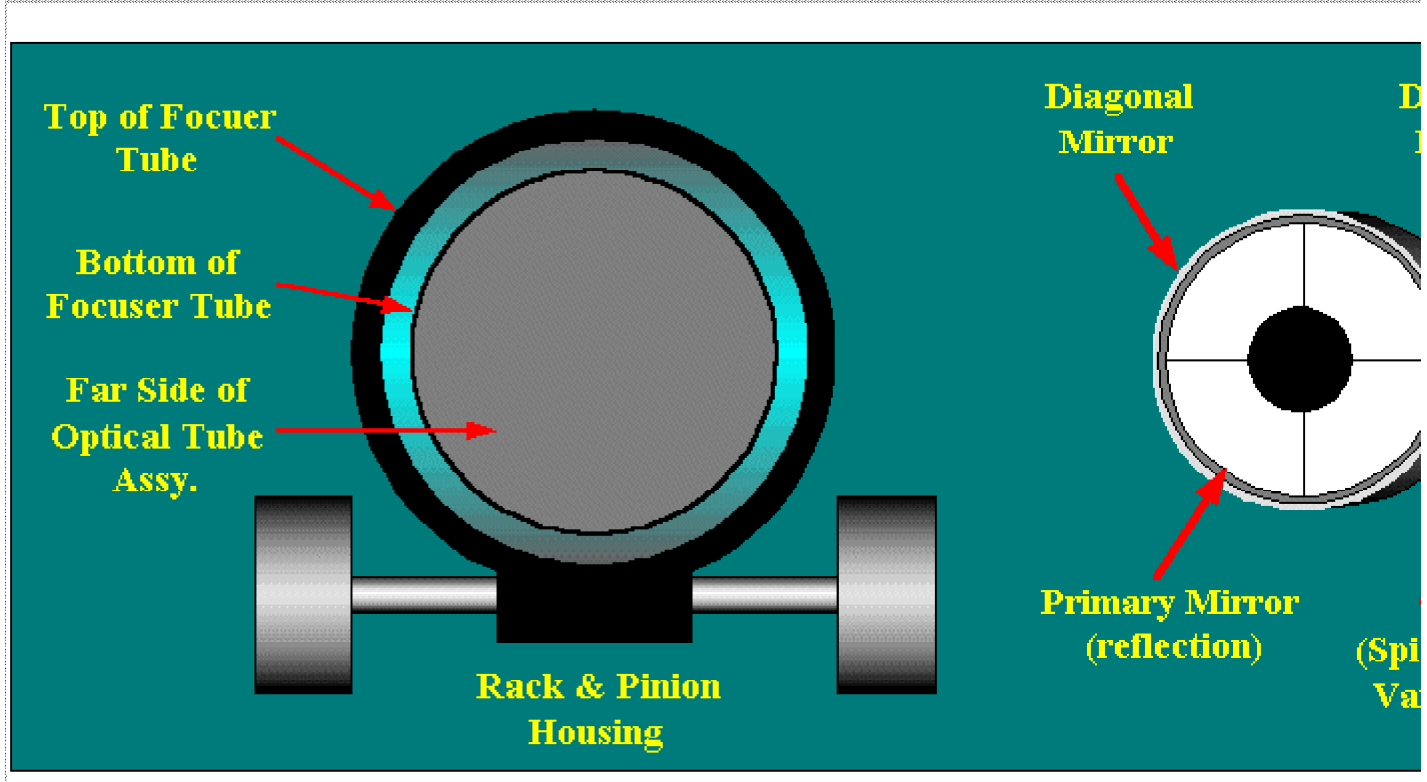

Figure 1b: Focuser Assembly & Diagonal with Holder and Spider Assembly.

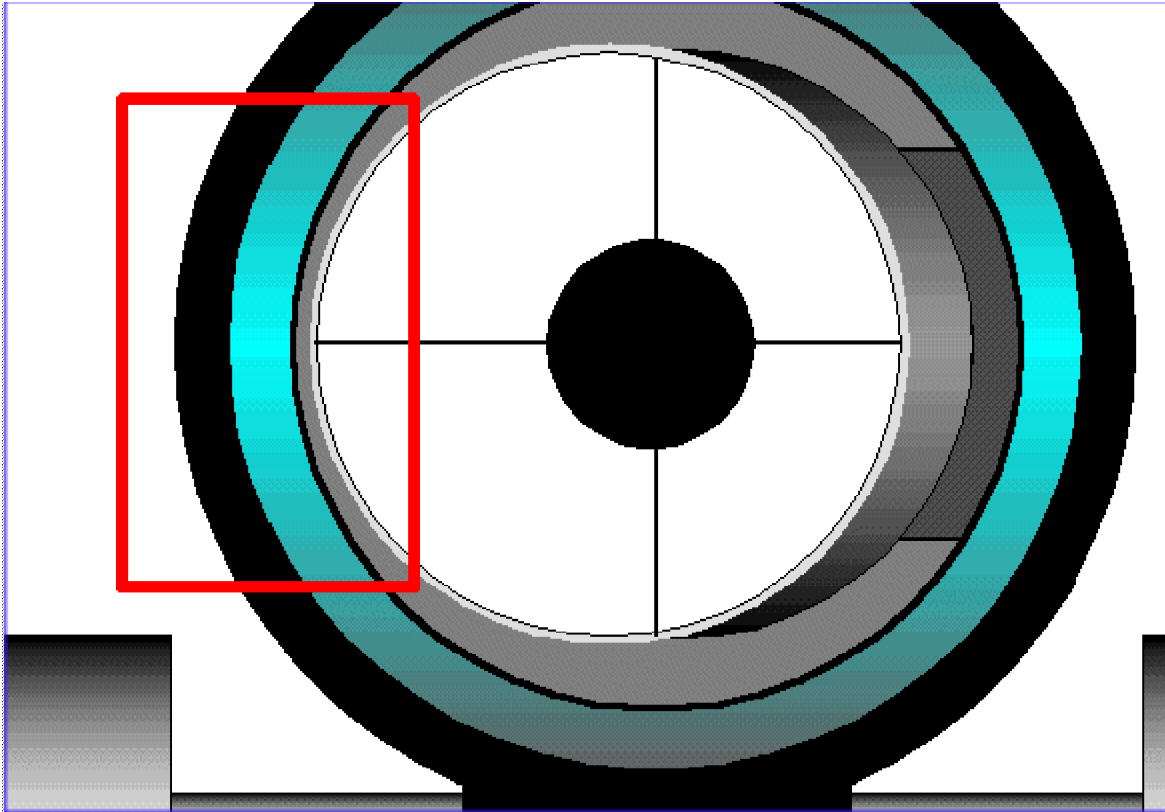

Figure 1d: **Diagonal Offset.** When viewing from a point about 6" outside the focuser tube, the a properly situated Diagonal Mirror will appear off-center with the focuser, shifted toward the Primary Mirror. Note however, that the Diagonal's reflection in the Primary Mirror will remain more or less centered.

### Points of View

If one were to view the diagonal from the point where the focal plane (usually within the focuser tube) meets the focuser tube axis, the **diagonal would seem centered**(see Figure 1). Yet it should be noted that when viewing from a point well outside the focuser tube (beyond the focal plane, but still on the focuser tube axis), that the **diagonal mirror will appear off-center** from the tube walls. The reflection of the primary mirror, however, will remain centered to the focuser, and not centered within the diagonal. (See Figure 1d.)

### 1. Checking Diagonal Alignment:

- |    |  |
|----|--|
| A. | In a well lit room or with the scope under a bright sky, remove the eyepiece and point the telescope at a bare wall, ceiling or clear sky. |
| B. | Place your eye about 6" from the focuser tube, looking straight down it toward the diagonal. (Refer to Figures 1, 2 & 3)                   |
| C. | Line up the near and far end of the focuser tubes as concentric circles. (See Figure 3)  |

No Tools Collimation

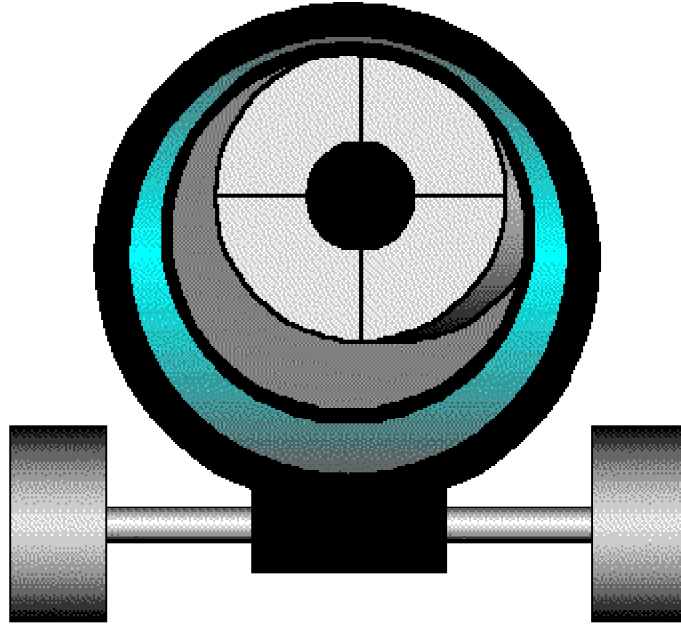

Figure 2: *WRONG! View is NOT ON AXIS of the focuser tube.*

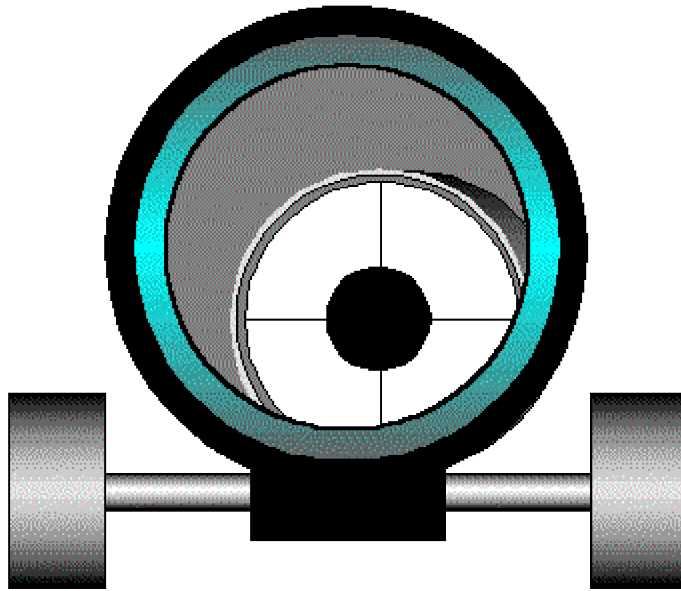

Figure 3: *View is good (on-axis of Focuser), but note that the Diagonal Mirror is not aligned (nearly-centered) with focuser axis.*

- D. The diagonal should reflect an image of the primary mirror, such that the primary and the focuser tube ends appear as concentric circles. (See Figure 1) *If this view cannot be achieved by moving the eye along the focuser tube axis, then the diagonal is out of alignment, and should*

*be corrected. (See your manual, for details.)*

## 2. Preliminary Primary Adjustment:

|    |  |
|----|--|
| A. | While the focuser tube ends and the primary mirror appear to be concentric, examine the position of the diagonal's reflection in the primary mirror. The diagonal's reflection should appear concentric with the other circles, or just slightly off-center (away from the focuser's reflected position.)  |
| B. | If this view is not achieved, the make small changes to the collimation-adjustment screws on the back side of the primary mirror's cell. (These are NOT the screws that bolt the mirror cell to the tube wall.) Again, check with the manual if these are not obvious. Also note that there are generally two types of collimation-adjustment mechanisms - spring-loaded (one screw per adjustment / three per mirror cell) and push-pull (two screws per adjustment with opposing actions). |
| C. | At the end, the Focuser View should appear very similar to Figure 1.   |

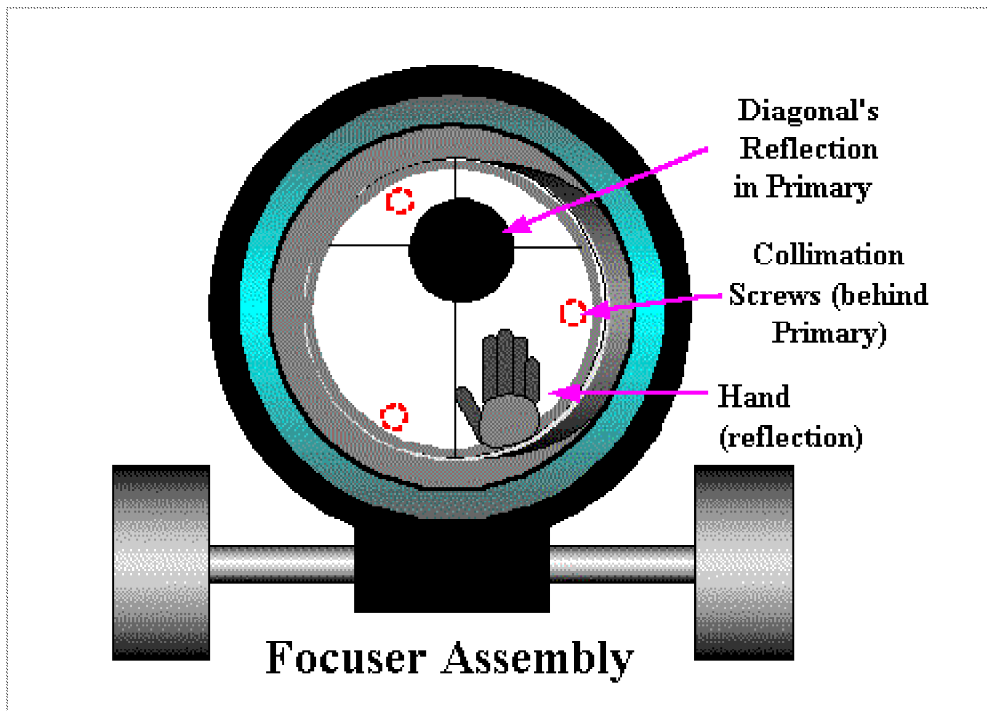
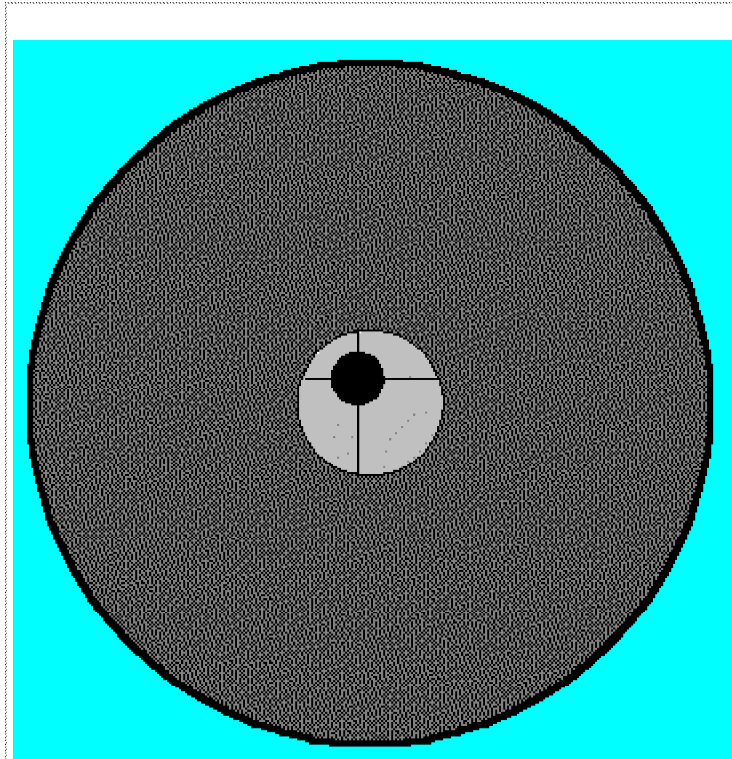

Figure 4: *Focuser View for rough collimation of Primary Mirror. (Note that Diagonal outline is concentric with focuser tube ends. Also, wave hand in front of tube, while watching for reflection. This will help you to orient which side of the tube reflections and collimation screws are referenced to.)*

### 3. Star-light Collimation:

- |    |   |
|----|---|
| A. | Under the night sky, find a reasonably bright star in the <u>low power</u> eyepiece (25mm or so) to start with. (Polaris is usually the best collimation star for most observers in the northern hemisphere.) |
| B. | Center the star in the field of view, then move the focuser inward, until the star appears as a uniformly bright donut. The size should be about that of a quarter held at arm's length. (See Figure 5 and 6) |



*Figure 5: Low-Power Eyepiece View of Defocused Star, with some Primary Mirror misalignment.*

No Tools Collimation

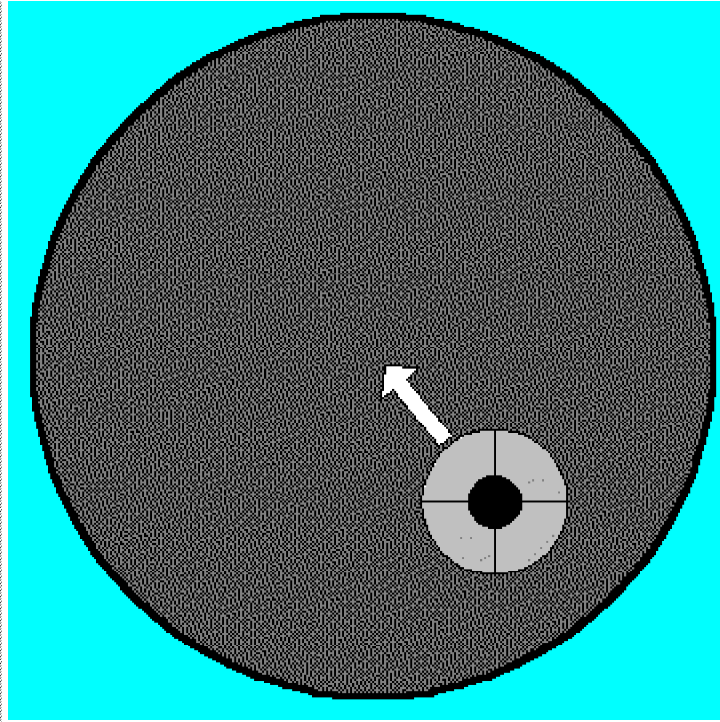

Figure 5a: *Finding the optical axis of the Primary Mirror. Move the defocused star around the field until the Diagonal's silhouette is centered in the bright disc. If not in center of field, make small adjustments to collimation screws on Primary Mirror Cell, until bright disc is centered, as in Figure 6.*

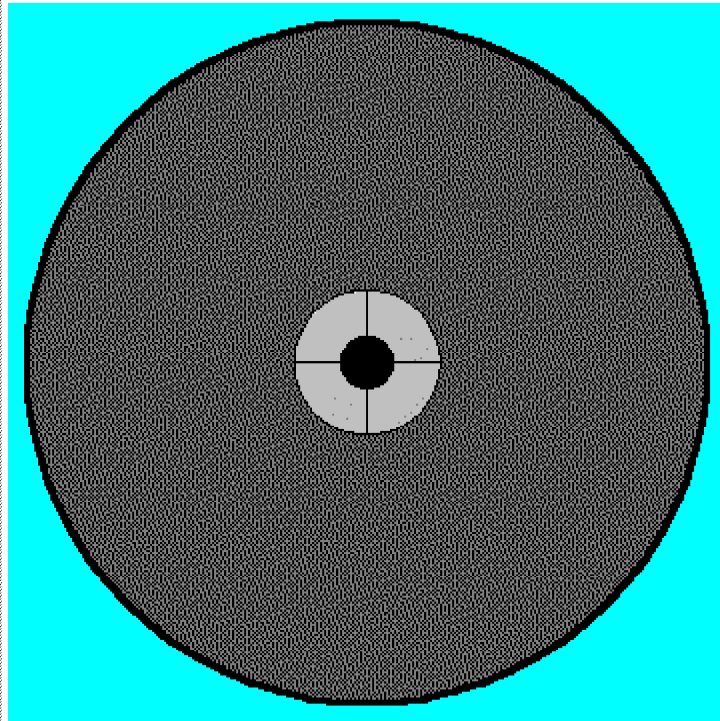

Figure 6: *Low-Power Eyepiece View of Defocused Star,*

No Tools Collimation

*with Primary Mirror in good collimation.*

|    |   |
|----|---|
| C. | The image seen is that of the diagonal's shadow falling on the primary mirror. If the star-donut is still centered in the field of view, then the image is an accurate representation of where the diagonal is relative to the incoming starlight.  |
| D. | Once again, the "hole" should appear more or less centered in the donut. If it isn't, align the primary mirror cell until it is. To do this, first move the defocused star around the eyepiece field until the diagonal's silhouette is centered in the bright disc. Carefully adjust the collimation screws on the Primary Mirror's cell, until the star-disc is moved to the center of the field. |
| E. | Move the focuser outward slowly. The donut should appear to collapse and brighten around a diminishing hole.  |
| F. | When the donut is about the size of dime held at arm's length, stop and inspect the circularity of the image. If the image is boiling wildly, then there are severe thermal or atmospheric conditions to contend with, and little further progress can be made. If there appears to be slow waving areas of shifting brightness, these are normal, and further collimation may continue.            |
| G. | Insert the highest power eyepiece (9mm or less, focal length). Recenter the star and find best focus.   |
| H. | Now defocus slowly until the star breaks into a smallish group of alternating bright and dark rings, formed around a dark hole. This is the alignment <i>target</i> , with its own built in bulls-eye. (See Figure 7)   |

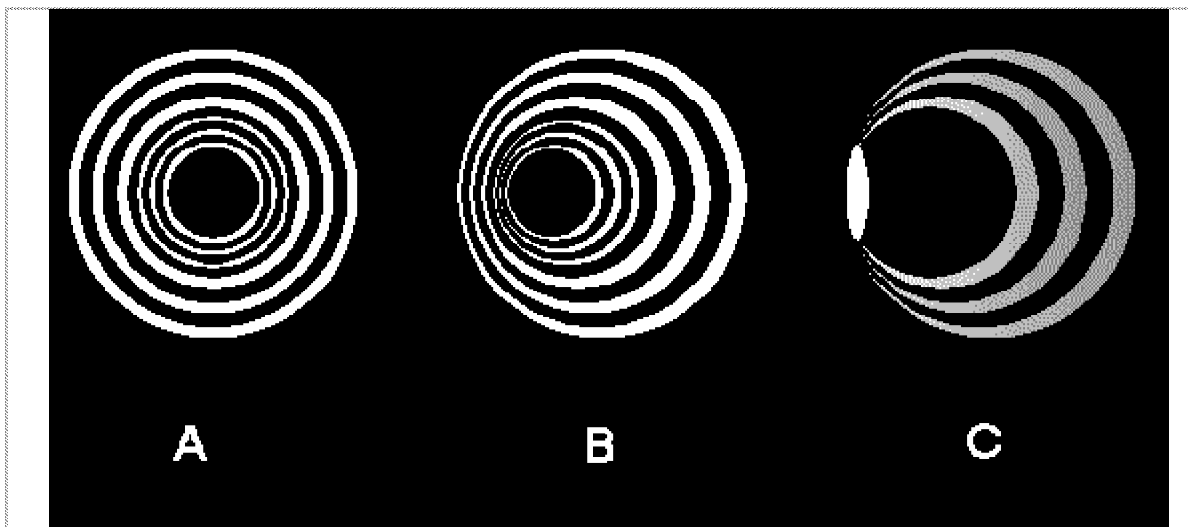

Figure 7: *Eyepiece views of defocused star at High Power, with differing degrees of misalignment:*

- A. Very Good Collimation*
- B. Slightly off-axis*
- C. More off-axis, out of collimation.*

**I. Final Adjustments .**

1. If the target is centered (in the field of view) but the bulls-eye is off to one side (Figures 7b and 7c), move the telescope slowly off-center until the defocused star appears as a series of concentric rings, as is shown in Fig. 7a.
2. Note the angular position of the star from the center of the field, and proceed to make small adjustments to the mirror cell's collimation screws.
3. After each quarter turn, or so, check the positioning of the target in the eyepiece, and note how the adjustment has shifted the star within the field. (left, right, up, down, toward center, or away).
4. If need be, undo the previous worsening, before making another attempt at improvement..
5. Continue improving the star's position within the field until it is fully centered.

- J.** Check the work, by slowly returning to best focus. The target rings should collapse around a shrinking center.

This procedure should be quite adequate for a good view of the moon and planets with a moderate power eyepiece (9mm focal length, or longer).

**Other Limiting Factors** - atmospheric turbulence, heat plumes and tube currents may yet cause problems, and should not be dismissed out of hand.

***Special Thanks***

Special thanks go to Dennis McGlasson, Alan Levin, Chuck Olson, Paul Cooper and others for reviewing and commenting upon this page, and suggesting corrections and other improvements.

---

***Copy / Distribute This Page***

In the two years since this page was first posted to the Internet, a number of amateur astronomers have expressed their regard for this page as useful reference for collimating Newtonian telescopes. Since the future hosting of these instructions is uncertain, you may find it desirable to save this page, along with its images for later reference. If you are a member of a club or organization and wish to mirror this page on your own site, that would also be a kind service to the community of amateur astronomers.

Limited Public Domain Statement - Any and all persons are hereby authorized to copy and/or distribute this webpage and its contents for either personal or not-for-profit use only. Any material copied from this page and presented in a modified or translated form should be properly attributed to its sources.

No Tools Collimation

Last Updated: February 10, 2005 - 2:30pm  
© 2004, 2005 Larry Gilstrap

---  
)-(